

## **STEELMAKING ON MARS**

**Shaun Moss**

shaunmoss@yahoo.com.au

### **ABSTRACT**

Steel is one of the most widely used materials on Earth, and is likely to be even more valuable on Mars, which lacks wood. Although locally-produced bricks, blocks and cement might initially predominate in construction, their low tensile strength limits what can be manufactured with these materials in the absence of reinforcing steel.

Steel will enable fabrication of buildings, parts for vehicles and machinery, beams, pipe, fasteners, tools, sheet metal, cooking implements, appliances, cutlery, and countless other things. The rate at which a martian society can expand will be strongly linked to the rate at which it can produce its own steel. Beyond agriculture, the manufacture of materials, especially steel, will be an important key to self-sufficiency on Mars.

Apart from iron ore, the major ingredients normally required for steelmaking are coking coal, limestone, and oxygen-rich air, all of which are in short supply on Mars. However, the basic elements of steel – namely, iron and carbon – *are* available, which suggests that steel can be manufactured on Mars from local ingredients using new methods.

In this paper, various different methods for manufacturing steel on Mars are investigated and compared. Although Mars has abundant quantities of alloying metals with which to produce different types of steel, the paper focuses on plain carbon steel, which is the most common type in use on Earth and will be the easiest to manufacture on Mars.

## **STEELMAKING ON EARTH**

### **Composition of Steel**

Steel is defined as an iron alloy which can be plastically formed. There are many different types of steel, but almost all contain between 0.05% and 2.1% carbon, which adds strength and hardness to the steel at the expense of ductility. Alloying elements such as chromium, nickel, magnesium and vanadium are often added to enhance different material properties. Depending on the type of steel, most of the silicon present in the original ore may be removed, or some may be retained. Sulphur and phosphorous are undesired, although small amounts usually remain in the finished product.

Mild (low carbon) steel, containing about 0.05% to 0.26% carbon, is the most common type of steel, due to its low cost and the fact that its material properties are suitable for many applications, including structural steel.

### **The Steelmaking Process**

Modern steelmaking plants are large and fully integrated, receiving iron ore and other ingredients at one end, and outputting steel product such as columns, plate and pipe at the other.

There are two basic categories of steel production on Earth:

1. Ore-to-steel, which uses a blast furnace (BF) and a basic oxygen furnace (BOF)
2. Scrap-to-steel, which uses an electric arc furnace (EAF)

It is the ore-to-steel process that will be needed first on Mars. On Earth, this begins with the mining of iron ore, produced as lump ore or fine ore. Fine ore cannot be directly refined, and must first be either pelletised or sintered; processes that agglomerate the fines into larger particles.

The iron is refined in a blast furnace, a vertical chamber lined with refractory bricks designed to withstand temperatures up to 2200°C. Coking coal is used for reduction of the iron oxide, and limestone is used as a flux, to remove silica and other contaminants. The ore, flux and coke are fed into the top of the furnace, and a blast of heated air is forced into the bottom.

#### Iron Oxide Reduction

The coke burns, maintaining the high temperatures required, and producing carbon monoxide:

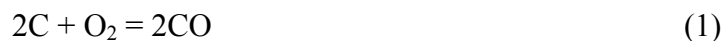

About 75% of the iron oxide (nominally hematite) is reduced by CO to metallic iron:

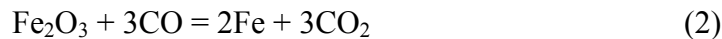

The remainder is reduced by carbon:



Some of the carbon combines with metallic iron to form iron carbide:



## Flux and Slag

The flux, which is mostly limestone (calcium carbonate,  $\text{CaCO}_3$ ), dissolves impurities in the iron ore. These are primarily silica ( $\text{SiO}_2$ ), as well as alumina ( $\text{Al}_2\text{O}_3$ ) and titanium oxide ( $\text{TiO}_2$ ). Other fluxes may be used depending on the impurities that need to be removed. Limestone decomposes to quicklime (calcium oxide,  $\text{CaO}$ ) in the heat of the furnace:



The quicklime then combines with silica to form slag:

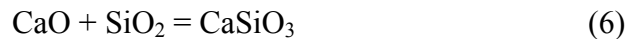

Being lighter than metallic iron, the slag floats on the surface of the molten metal and can be separated.

## Removal of Excess Carbon

The resultant iron, known as pig iron, contains up to 7% dissolved carbon. Excess carbon is removed in the BOF, with limestone flux again added as a slag former.

In the BOF, oxygen is blown into the molten iron, oxidising dissolved carbon to carbon monoxide gas, as in reaction (1). Other impurities are oxidised to acidic oxides, which combine with flux to form slag. This process is continued until the desired concentration of carbon is obtained and the amounts of impurities have been reduced to tolerable levels. Other alloying ingredients may then be added to produce a specific type of steel.

The steel is cast into continuous strands, which are then cut to length, heat treated, extruded, rolled and/or pounded to produce different products.

## **STEELMAKING ON MARS**

The martian surface owes its rusty hue to the ubiquitous iron oxide, so there is clearly a great abundance of iron on Mars, and ore-bearing regolith will be relatively easy to obtain using ordinary mining equipment such as front-end loaders. More elaborate methods such as open-pit or underground mining may be required in the future to access higher-grade ore.

Five different options for making steel from martian iron ore are investigated and compared:

### **1. Carbon Method**

2. **Carbon Monoxide Method**
3. **Methane Method**
4. **Hydrogen Method**
5. **Carbonyl Method**

## 1. CARBON METHOD

In this approach, the usual ingredients required for steelmaking are first manufactured from the martian environment, which allows more-or-less the same processes and equipment as used on Earth to be employed.

### 1.1 Manufacturing Carbon

The cheapest and easiest way to make carbon on Mars is from CO<sub>2</sub> and H<sub>2</sub> via the Bosch reaction, which is exothermic and occurs in the presence of an iron, cobalt or nickel catalyst at temperatures between 450°C and 600°C:



This is actually a combination of two reactions:



Reaction (8) is known as the reverse water gas shift (RWGS) reaction, which occurs fairly fast. Reaction (9) is slow, however, and controls the overall rate of the Bosch reaction. Water must be continually removed from the reaction chamber in order to drive the reaction to the right.

### 1.2 Obtaining Carbon Dioxide

CO<sub>2</sub> is easily obtained from the martian air, which is approximately 95% CO<sub>2</sub>, 2.7% N<sub>2</sub>, 1.6% Ar, plus trace elements of other gases. A filter is attached to the intake pump to remove most of the dust particles. The air is then compressed to about 700kPa and allowed to equilibrate to ambient martian temperatures. This liquefies the CO<sub>2</sub> so it can be separated from the other gases.<sup>[1]</sup>

This process is likely to be in large-scale use on Mars before steelmaking is attempted. CO<sub>2</sub> will be required for the manufacture of methane fuel (CH<sub>4</sub>)<sup>[1]</sup>, and the remaining gases could be mixed with oxygen to produce breathable air.

### 1.3 Electrolysis

Hydrogen for reaction (7) and oxygen for the furnaces can be easily obtained from the electrolysis of water:

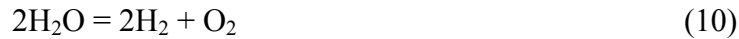

Electrolysis is another process which is very likely to be in large-scale use on Mars, as a means of providing hydrogen for methane production, and oxygen for rocket fuel and breathable air. Electrolysis technology is already very advanced, highly efficient, and used in space. As long as issues related to long-term storage of these gases on the martian surface can be addressed, it is reasonable to expect that supplies of both hydrogen and oxygen will be ample.

Water for reaction (10) is available in abundance on Mars, frozen in the regolith and polar caps, and possibly available as a liquid in underground aquifers. By the time steel is being produced on Mars, it is likely that colonists will have already developed methods for mining and purifying water from these reservoirs. Water produced by reaction (7) can also be recycled, and if regolith containing ice or hydrated minerals is used as ore, heating this ore will release water which can be captured.

#### 1.4 Carbonates and Flux

The final ingredient we require for the typical steelmaking process is flux. Typical fluxes are limestone ( $\text{CaCO}_3$ ), magnesite ( $\text{MgCO}_3$ ), dolomite ( $\text{CaMg}(\text{CO}_3)_2$ ), or some combination of these. On Earth, the main ingredient is usually limestone, although magnesite and dolomite produce practically the same results.

If Mars has had a watery past, as the evidence suggests, then concentrated deposits of carbonates are also expected. However, these have not yet been detected. Carbonates seem to be distributed more-or-less evenly across the planet, forming about 2-5% of the ubiquitous dust. It has been suggested that this may be the result of erosion of exposed magnesite by the perpetual martian winds and distribution of the grains across the planet's surface, and that concentrated carbonate deposits may yet be discovered below the dust layers. Although it is not yet known exactly what types of carbonates are contained in the martian dust, the thermal emission spectra most closely match that of 3% magnesite.<sup>[2]</sup>

If magnesite is the dominant carbonate on Mars, then the most important reactions involved in slag production will be:



martian dust is available in vast quantity and is easily mined. If dust or regolith deposits are found that include high concentrations of carbonates as well as high grade iron ore, it may not be necessary to add extra flux.

#### 1.5 Discussion

Manufacturing solid carbon in this way is not really desirable. Elemental carbon (graphite) builds up on the catalyst, inhibiting the efficiency of the reaction. An automated mechanical process would be required whereby most of the carbon is scraped off the catalyst and any remaining residue removed using carbon dioxide gas (this residue would be lost, further reducing efficiency). This would be a slow and inefficient process, and has more potential for problems than gas-handling techniques.

It would also be difficult to implement this process if Mars does not have concentrated deposits of carbonate minerals.

## **2. CARBON MONOXIDE METHOD**

In the previous method, carbon and oxygen are manufactured from martian air only to be recombined into carbon monoxide, the actual reducing gas, in the furnace. However, the manufacture of CO is much faster, easier and more efficient than the manufacture of carbon, and, being gaseous, it is also much easier to handle and does not require mechanical removal from a catalyst.

### **2.1 Making Carbon Monoxide**

There are two main ways that carbon monoxide can be manufactured on Mars. The first is via the RWGS reaction mentioned earlier:



This reaction is slightly endothermic and occurs at 400°C in the presence of an iron-chrome catalyst. Again, hydrogen for the reaction is easily obtained via electrolysis, and the water produced can be recycled back into the electrolysis plant.

Another method for manufacturing carbon monoxide is the reduction of carbon dioxide by heating it to 1100°C:



The CO and O<sub>2</sub> can be separated by electrochemically pumping the oxygen across a zirconia ceramic membrane. This has been proposed as a method of oxygen manufacture<sup>[1]</sup>, although, due to the complex and fragile nature of the necessary equipment, it may be challenging to implement this process at an industrial scale. For this reason reaction (8) is probably preferable, especially considering the lower energy requirements.

### **2.2 Energy**

Using carbon monoxide as a reducing agent means that neither coke nor oxygen-rich air is required in the furnace. However, in traditional steelmaking the burning of coke

produces heat which powers the reduction reactions and melts the iron. For this approach to work, then, a different kind of furnace would be required that provides this heat energy some other way. This may resemble an electric arc furnace (EAF), in which the energy to melt scrap steel is delivered through graphite electrodes.

### **2.3 Adding Carbon**

In traditional steel manufacture, too much carbon is dissolved in the iron during the refining process, and the excess is removed in the blast oxygen furnace. However, the iron produced using carbon monoxide will not contain dissolved carbon, hence some will need to be added.

Another item of plant would thus be required, where carbon and possibly other alloying elements would be added to the molten iron from the CO-furnace. A furnace resembling an EAF, which has the advantage of being able to finely control steel chemistry, may suit this purpose.

The small amount of required carbon (from 0.05% to 0.26% for mild steel) could be manufactured as described above in the Carbon Method. However, to avoid manufacturing solid carbon, another possible technique for adding carbon into the iron would be to introduce  $\text{CO}_2$  and  $\text{H}_2$  to the furnace, and to induce the Bosch reaction (7). Both of these gases are relatively cheap on Mars, and the iron would act as a catalyst for the reaction.

The Bosch reaction is exothermic and could provide enough heat to maintain the desired furnace temperature. The water produced can be captured and recycled back to the electrolysis plant.

However, this reaction occurs at lower temperatures than the melting point of iron. This could mean that the iron would need to first be cooled and solidified (possibly into some high-surface-area shape), and then, after a layer of carbon had formed, melted again to mix the iron and carbon. This procedure would be costly in terms of time and energy. There may, however, be a way to induce the Bosch reaction in the presence of molten iron, for example, by pressurizing the furnace.

## **3. METHANE METHOD**

On Earth there is another process of iron refining known as Direct Reduction (DR), which uses natural gas (primarily methane,  $\text{CH}_4$ ) instead of coal.<sup>[3]</sup> More efficient and environmentally-friendly, DR is becoming an increasingly popular technology. The iron produced in this manner is known as Direct Reduced Iron (DRI), and is typically added to EAFs along with scrap steel to increase productivity. In areas where supply of scrap is limited, some steel plants use up to 95% DRI in EAFs<sup>[4]</sup>. This statistic suggests that it may be possible to use 100% DRI to produce steel in an EAF.

The standard DR process only reduces the iron oxides. A DR furnace (the “shaft furnace”) operates at temperatures below the melting point of iron, which means slag cannot be formed, and so flux is not used. The ore must therefore usually be high grade, that is, relatively low in impurities. DRI contains about 85% metallic iron, with the remainder comprised of unreduced iron oxide (about 6%), carbon (1% - 3.5%), silica and other impurities.

The DR approach might be practical on Mars if methane is being manufactured in industrial-scale quantities, which may indeed be the case, since methane has been proposed as a cheap locally-produced fuel for spacecraft and rovers. Processes for methane manufacture on Mars have already been closely examined and experimentally verified.<sup>[1]</sup>

### 3.1 Chemistry of Methane Manufacture

Methane can be easily produced on Mars using the Sabatier (methanation) reaction:



This reaction is exothermic, which means no energy is required, and is driven strongly to the right. Furthermore, the required equipment is cheap and simple, and so, considering the low cost of the reactants, methane will be relatively inexpensive to manufacture on Mars.

### 3.2 Chemistry of Direct Reduction

In a DR plant, methane is partially oxidised to form reducing gases:



Carbon monoxide and hydrogen reduce the iron oxide as follows:

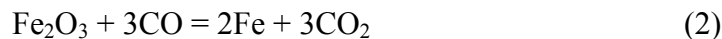

The  $\text{CO}_2$  and  $\text{H}_2\text{O}$  produced by the reduction reactions are recycled into a reformer, and reacted with methane to produce more reducing gas:



Carburisation occurs as follows:

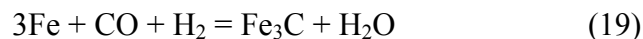



DRI contains from 1% to 3.5% carbon. This is less than pig iron, hence less oxygen is required to reduce carbon levels.

See *Figure 1: The Midrex Direct Reduction Process*.

### 3.3 Advantages

This method of steelmaking offers some significant advantages over the previous two. It does not require manufacture of solid carbon, or the untested method of using the Bosch reaction to add carbon. It is also a well-understood and verified process, having been in development and use for approximately 35 years.

Another benefit is that methane is a very useful substance, and nothing can be lost by manufacturing it in quantity. Aside from fuel, it can also be used for making plastics and other hydrocarbons and organic molecules, and any surplus can always be safely dumped into the atmosphere, since methane is a reasonably good greenhouse gas which encourages ozone production.

### 3.4 Process Diagrams

*Figure 2* is a flow diagram showing production of the basic substances required by a Mars base, such as fresh water, breathable air, and methane fuel. These elements of a Mars colony are likely to be well-established before any attempts at steelmaking.

*Figure 3* shows a simplified material flow through a steelmaking plant that uses the Methane Method. Two mines are required, assuming (perhaps optimistically) that concentrated magnesite deposits will be discovered below the surface dust. All flue gases are collected and recycled, and slag can be reused in the same ways as it is on Earth: as a cement replacement, or to enrich nutrient-deficient soils.

## 4. HYDROGEN METHOD

As the DR process shows, hydrogen can be used to reduce iron oxide:



Because hydrogen is cheaper than both methane and carbon monoxide on Mars, it may be a worthwhile alternative.

### 4.1 Low-Temperature Furnace

A DR shaft furnace can directly reduce solid iron ore using only hydrogen. Midrex DRI furnaces can operate with any ratio of H<sub>2</sub> and CO reducing gases, from 100% H<sub>2</sub> to 100% CO<sup>[5]</sup>. As usual, water produced by reaction (16) could be captured and cycled back to the electrolysis plant to produce more hydrogen.

The disadvantage would be that the resultant “pseudo-DRI” would not contain any carbon. This is the same problem as described in section 2.3, and thus an extra process would be required to introduce carbon. It is questionable whether the costs saved by using hydrogen instead of methane would outweigh the extra costs incurred by a carbon-addition process.

#### 4.2 The “H<sub>2</sub>-CO<sub>2</sub> Furnace”

There may, however, be a neat solution. As described in section 2.3, it may be possible to produce carbon in a chamber containing solid iron by introducing H<sub>2</sub> and CO<sub>2</sub> gases and inducing the Bosch reaction.



As carbon is produced, iron carbide would form as follows:



If reaction (16) can occur at the same temperature as the Bosch reaction, it may be possible to reduce the iron ore while simultaneously producing carbon and iron carbide.

The usual temperature inside a modern DRI shaft furnace is in excess of 1000°C, which is higher than the range for reaction (7), although shaft temperatures have been increased over the years in order to improve productivity, and in the early days of DRI, shaft temperatures were only around 780°C<sup>[6]</sup>.

Since higher shaft furnace temperatures improve productivity, it is probably preferable to perform these operations as separate phases. The iron ore would first be reduced by introducing hydrogen into the furnace at a higher temperature, before lowering the temperature of the furnace to below 600°C, and then injecting both H<sub>2</sub> and CO<sub>2</sub> in order to produce the desired level of carbon.

Because the amount of carbon (in the form of CO<sub>2</sub>) being added to the chamber can be precisely controlled, it should be possible to produce DRI with close to the exact desired concentration of carbon, thus largely or wholly eliminating the carbon-reduction step.

As with regular DRI, an EAF would still be required to melt the DRI, remove impurities, and fine-tune the chemistry of the steel. See *Figure 4*.

#### 4.3 High-Temperature Furnace

Another alternative could be to use H<sub>2</sub> instead of CO (as described in the Carbon Monoxide Method) in a high-temperature modified blast furnace. In this case, the ore would be molten during the reduction phase, allowing flux to be added, slag to be

formed, and impurities removed. This approach would enable the use of lower-grade ore, however, the problem of adding carbon to the molten iron would remain.

## 5. CARBONYL METHOD

There is a technique known as chemical vapour metal refining, used for production of high-purity iron, nickel and other metals.

### 5.1 Chemical Vapour Iron Refining

The iron ore must first be reduced, using, for example, DR. Carbon monoxide gas is then pressurised with the DRI, and combines with iron atoms to form iron pentacarbonyl gas:

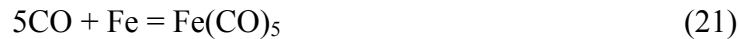

This gas is piped into another chamber with warm surfaces (about 120°C), where the iron pentacarbonyl dissociates, depositing a layer of almost pure (97.5 – 99.5%) iron on the chamber surfaces. The CO gas released is then recycled back into the first chamber to pick up more iron atoms.

### 5.2 Advantages

There are several advantages associated with this technique of metal refining:

- Highly pure metals can be produced.
- Temperatures, and therefore energy requirements, are relatively low.
- It is possible to go directly from ore to part by depositing iron directly onto a shaped mould.
- Flux is not required.

If Mars does not have concentrated deposits of carbonates to use as flux, then this process could form an essential part of the martian steelmaking process. Even if Mars does have carbonates, chemical vapour refining will probably still be significantly more efficient than the alternatives, considering the low energy requirements, and the fact that carbonates would not need to be located and mined.

### 5.3 Producing Carbon Monoxide

On Mars, the reverse water gas shift reaction can be used to produce the required carbon monoxide relatively easily and cheaply, as described in section 2.1:



Because the CO is highly recyclable within the process, ongoing CO requirements are minimal once the initial volume is obtained.

## 5.4 Reducing the Iron Ore

A traditional DRI plant can be used to reduce the iron oxides, as described in the Methane Method. However, because the chemical vapour refining process extracts only the metal atoms, it will not matter if the DRI contains carbon, since any carbon atoms will be left behind with the other impurities. A cheaper alternative would be to directly reduce the iron ore using pure hydrogen as described in section 4.1.

Alternatively, if the steelmaking plant already has a carbon monoxide factory on-site, it might even be cheaper to use pure CO instead.

## 5.5 Adding Carbon – Ore to Steel

Once the iron is extracted from the DRI, again we have the problem of adding the small amount of carbon required to make steel. If the Bosch reaction is to be used for this purpose as described in section 2.3, then the temperature will first need to be increased to at least 450°C. Once the Bosch reaction is initiated, the heat produced should maintain the required temperature.

Since the deposition chamber already contains CO gas, an interesting alternative method for producing the required carbon may be to use reaction (9) instead, simply by introducing some H<sub>2</sub> into the chamber:



This reaction is exothermic, and therefore should help to maintain the temperature of the chamber.

Ideally, deposition of iron and carbon can occur simultaneously. This would result in the production of high-purity steel containing evenly distributed carbon, without requiring melting temperatures.

Reaction (9) is slow, and water would have to be continuously removed from the chamber in order to drive the reaction. The reaction rate may not be a major issue, however, because only a very small amount of carbon is required compared with the volume of iron. The amount of hydrogen injected into the chamber can be adjusted in order to deposit carbon at the required rate, and in fact it should be possible to finely control the carbon concentration.

Carbonyl iron refining is promoted as a method for making iron parts directly from ore, without melting, by using shaped moulds. Using the process described here, it may be possible to directly manufacture steel parts. Rolling or extrusion of this “carbonyl steel” may improve its properties as desired, or the steel could be melted in order to introduce other alloying elements. It may also be possible to use chemical vapour refining techniques to deposit other alloying elements simultaneously with the iron, thus producing high-purity alloys without melting.

See *Figure 5* for a flow diagram illustrating this process, with hydrogen used for reduction of the iron ore, and reaction (9) for adding carbon.

## CONCLUSIONS

Several different methods for manufacturing steel on Mars have been investigated and compared.

Direct reduction using methane seems to hold significant promise, since the gas can be easily and cheaply manufactured from local martian ingredients, has multiple uses, and the technology for making steel in this way is already well-developed.

Another method which appears to merit further investigation utilises a mixture of hydrogen and carbon dioxide, cheap reactants on Mars, in a new type of furnace. However, this is a purely hypothetical approach, and more research is required to determine its feasibility.

Chemical vapour metal refining techniques may be the best choice for Mars, especially if concentrated deposits of carbonates cannot be located or are not cost-effective to mine. Preliminary reduction of the iron ore can take place in a conventional DR plant using hydrogen gas. If iron and carbon can be simultaneously deposited in the same chamber, then it may even be possible to manufacture extremely high-purity carbon steel directly from DRI, without ever having to melt the iron.

## REFERENCES

1. Zubrin, R., *The Case for Mars*, Touchstone, New York (1996)
2. Martel, Linda M.V., *Show Me the Carbonates*, Planetary Science Research Discoveries, Hawai'i Institute of Geophysics and Planetology (2003). (<http://www.psr.d.hawaii.edu/Oct03/carbonatesMars.html>)
3. Midrex Technologies, Inc., *The World of Direct Reduction*, Charlotte, NC, USA.
4. Nabil Daoud Takla, Qatar Steel Company Ltd. (QASCO), *Utilization of Sponge Iron in Electric Arc Furnaces*, AISU 2<sup>nd</sup> Electric Furnace Symposium, 1998.
5. Cheeley, Rob B., *Gasification and the Midrex Direct Reduction Process*, Midrex Direct Reduction Corporation, Midrex 3<sup>rd</sup> Quarter 1999.
6. Tennes, Winston L., Gary E. Metius, John T. Kopfle, *Breakthrough Technologies for the New Millenium*, Midrex Technologies, Inc., Charlotte, NC, USA.

# IMAGES

**Figure 1. The Midrex Direct Reduction Process**

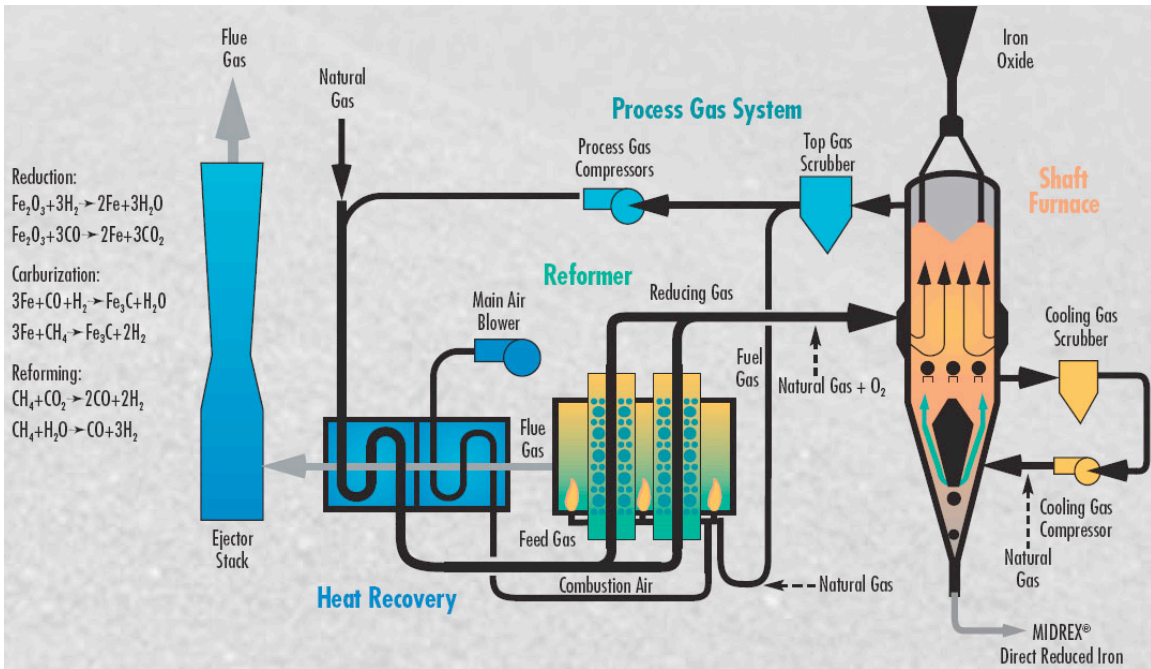

**Figure 2. Marsbase Materials Flow**

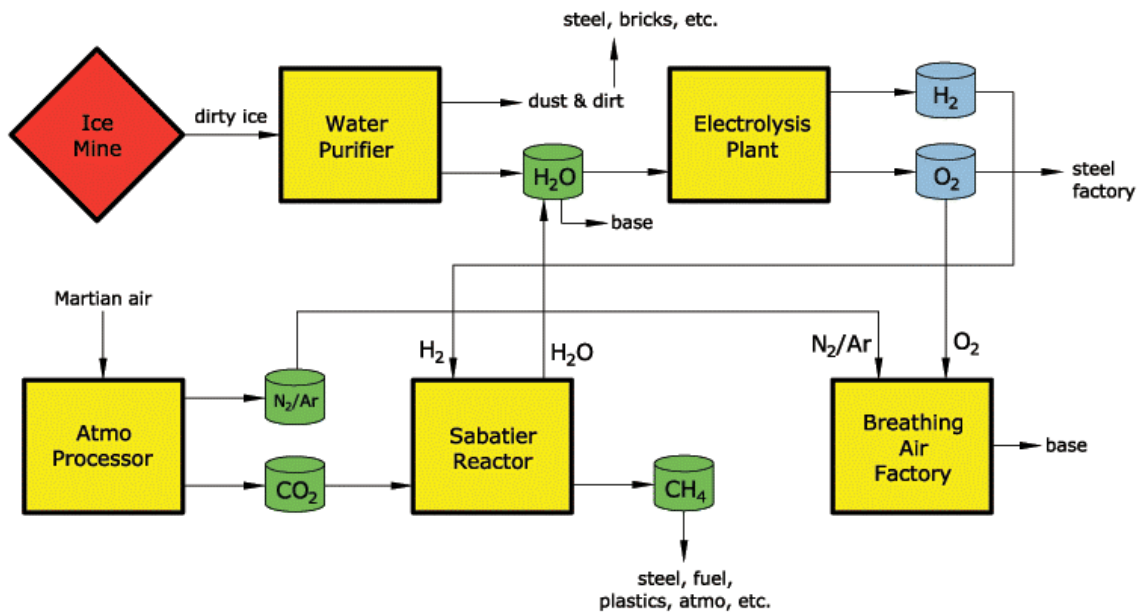

Figure 3. Steelmaking Plant Flow Diagram – Methane Method

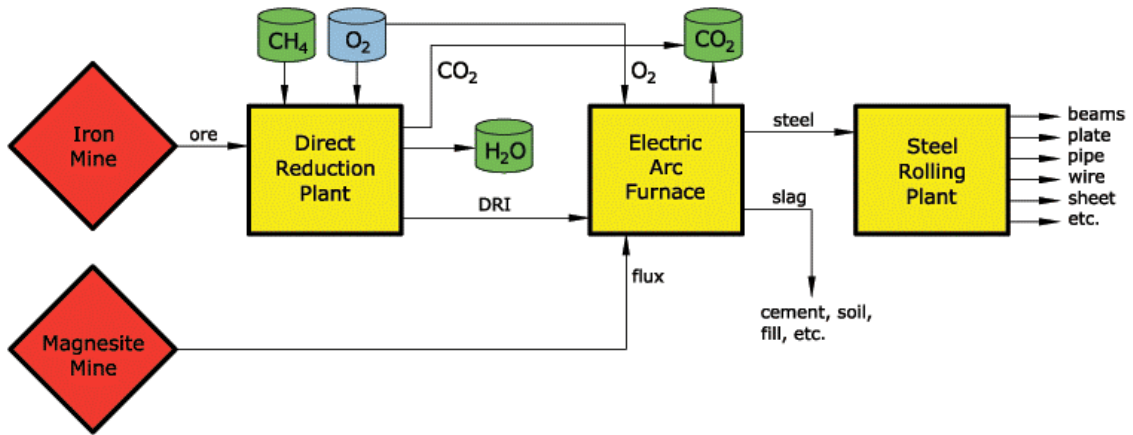

Figure 4. Steelmaking Plant Flow Diagram – Hydrogen Method

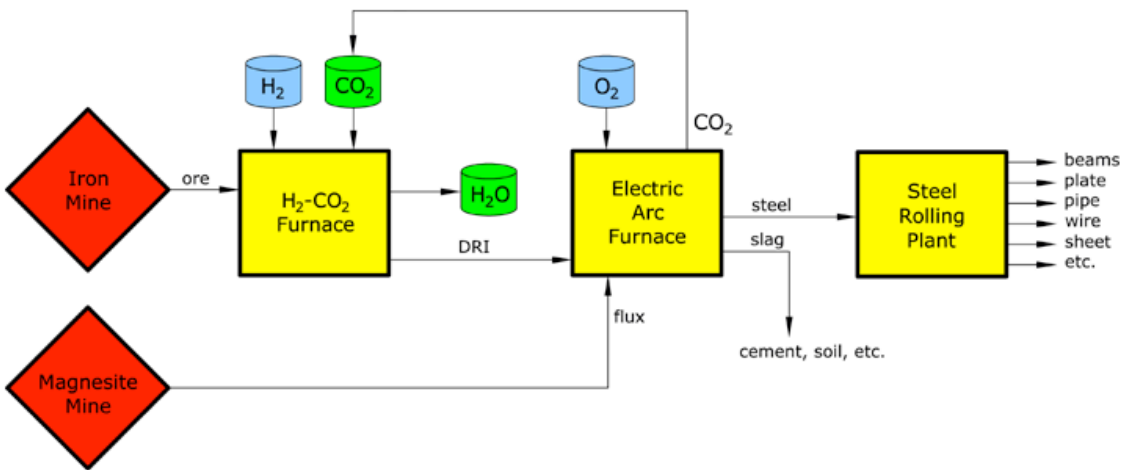

Figure 5. Steelmaking Plant Flow Diagram – Carbonyl Method

